



Lean-Gimn Enterprise Co., Ltd.

Data Sheet

Customer: _____

Product Type: High Voltage Thick Film Chip Resistor - HVR Series

Size: 0402/0603/0805/1206/2010/2512

Issued Date: 12-Nov-10

Edition: REV.A8



Produced by (QC)	Checked (QC)	Approved by (QC)	Prepared by (Sales)	Accepted by (Customer)
12-Nov-10	12-Nov-10	12-Nov-10	12-Nov-10	
Frank Lin	Amy Wu	Eagle Chen		



Lean-Gimn Enterprise Co., Ltd.

High Voltage Thick Film Chip Resistor (HVR Series)

Scope

– This specification applies to all sizes of rectangular-type fixed chip resistors with Ruthenium-base as material.

Features

- Highly reliable multilayer electrode construction
- Higher component and equipment reliability
- Excellent performance at high voltage
- Reduced size of final equipment

Applications

- Inverter
- Outdoor Equipments
- Converter
- Automotive Industry
- High Pulse Equipment



Construction

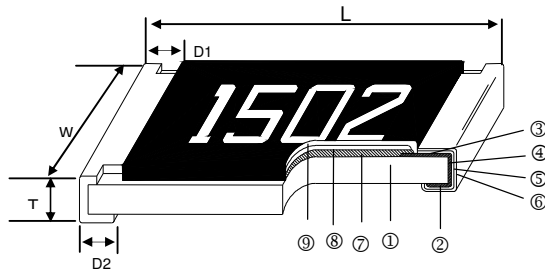

① Alumina Substrate	④ Edge Electrode (NiCr)	⑦ Resistor Layer (RuO ₂ /Ag)
② Bottom Electrode (Ag)	⑤ Barrier Layer (Ni)	⑧ Primary Overcoat (Glass)
③ Top Electrode (Ag-Pd)	⑥ External Electrode (Sn)	⑨ Secondary Overcoat (Epoxy)

Dimensions

Unit:

mm

Type	Size (Inch)	L	W	T	D1	D2	Weight (g) (1000pcs)
HVR02	0402	1.00±0.05	0.50±0.05	0.35±0.05	0.20±0.10	0.20±0.10	0.620
HVR03	0603	1.60±0.10	0.80±0.10	0.45±0.10	0.30±0.20	0.30±0.20	2.042
HVR05	0805	2.00±0.10	1.25±0.10	0.50±0.10	0.35±0.20	0.40±0.20	4.368
HVR06	1206	3.10±0.10	1.55±0.10	0.55±0.10	0.50±0.25	0.50±0.20	8.947
HVR0A	2010	5.00±0.10	2.50±0.15	0.55±0.10	0.60±0.25	0.50±0.20	24.241
HVR12	2512	6.35±0.10	3.10±0.15	0.55±0.10	0.60±0.25	0.50±0.20	39.448

Part Numbering

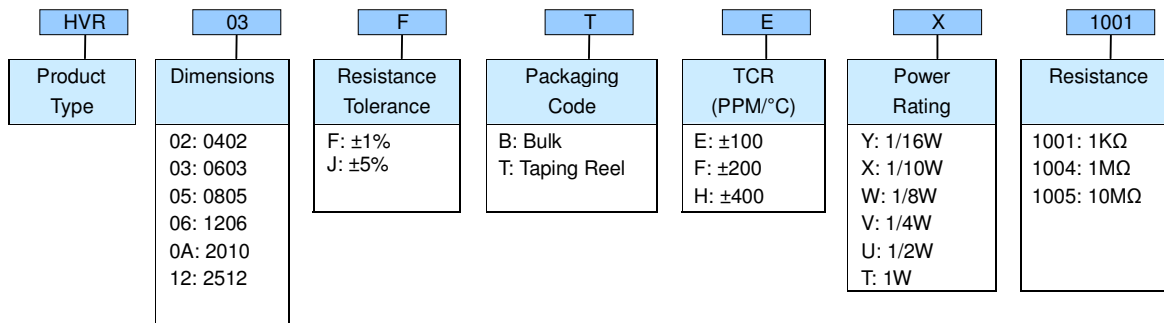

Derating Curve

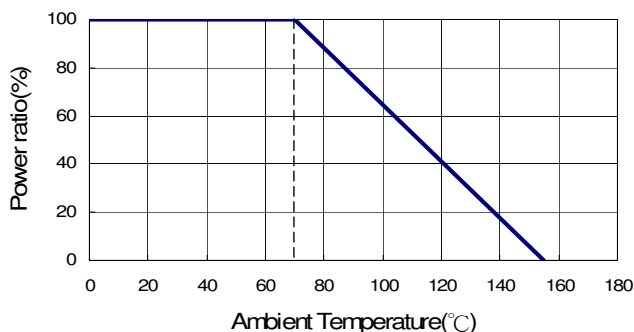

Standard Electrical Specifications

Type	Item	Power Rating at 70°C	Operating Temp. Range	Max. Operating Voltage	Max. Overload Voltage	Resistance Range		TCR (PPM/°C)
						±1%	±5%	
HVR02 (0402)	1/16W	100V	200V	100V	200V	10Ω - 1MΩ		±100
						1.02MΩ - 10MΩ	1.1MΩ - 20MΩ	±200
						-	22MΩ - 100MΩ	±400
HVR03 (0603)	1/10W	200V	400V	200V	400V	10Ω - 1MΩ		±100
						1.02MΩ - 10MΩ	1.1MΩ - 20MΩ	±200
						-	22MΩ - 100MΩ	±400
HVR05 (0805)	1/8W	400V	800V	400V	800V	10Ω - 1MΩ		±100
						1.02MΩ - 10MΩ	1.1MΩ - 20MΩ	±200
						-	22MΩ - 100MΩ	±400
HVR06 (1206)	1/4W	500V	1000V	500V	1000V	10Ω - 1MΩ		±100
						1.02MΩ - 10MΩ	1.1MΩ - 20MΩ	±200
						-	22MΩ - 100MΩ	±400
HVR0A (2010)	1/2W	2000V	3000V	2000V	3000V	10Ω - 1MΩ		±100
						1.02MΩ - 20MΩ	1.1MΩ - 20MΩ	±200
						-	22MΩ - 100MΩ	±400
HVR12 (2512)	1W	3000V	4000V	3000V	4000V	10Ω - 1MΩ		±100
						1.02MΩ - 20MΩ	1.1MΩ - 20MΩ	±200
						-	22MΩ - 100MΩ	±400

Operating Voltage= $\sqrt{P \cdot R}$ or Max. operating voltage listed above, whichever is lower.

Overload Voltage= $2.5 \cdot \sqrt{P \cdot R}$ or Max. overload voltage listed above, whichever is lower.

■ Viking is capable of manufacturing the optional spec based on customer's requirement.

■ Soldering Condition

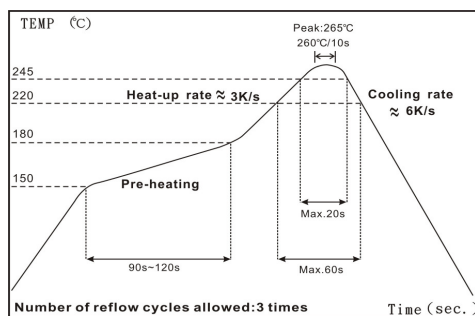

IR Reflow Soldering

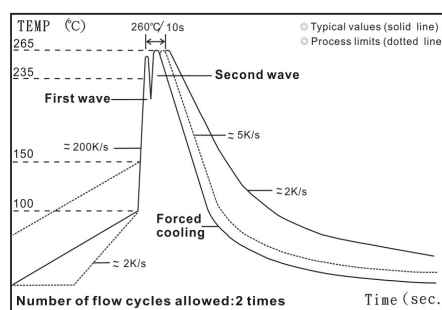

Wave Soldering (Flow Soldering)

- (1) Time of IR reflow soldering at maximum temperature point 260°C : 10s
- (2) Time of wave soldering at maximum temperature point 260°C : 10s
- (3) Time of soldering iron at maximum temperature point 410°C : 5s

■ Environmental Characteristics

Item	Requirement		Test Method
	1%	5%	
Temperature Coefficient of Resistance (T.C.R.)	As Spec.		JIS C 5201-1 4.8 IEC 60115-1 4.8 -55°C~+125°C, 25°C is the reference temperature
Short Time Overload	$\pm(1.0\%+0.05\Omega)$	$\pm(2.0\%+0.05\Omega)$	JIS C 5201-1 4.13 IEC 60115-1 4.13 RCWV*2.5 or Max. overload voltage for 5 seconds
Insulation Resistance	$\geq 10\text{G}$		JIS C 5201-1 4.6 IEC 60115-1 4.6 Max. overload voltage for 1 minute
Endurance	$\pm(2.0\%+0.10\Omega)$	$\pm(3.0\%+0.10\Omega)$	JIS C 5201-1 4.25 IEC 60115-1 4.25.1 70 \pm 2°C, Max. working voltage for 1000 hrs with 1.5 hrs "ON" and 0.5 hrs "OFF"
Damp Heat with Load	$\pm(2.0\%+0.10\Omega)$	$\pm(3.0\%+0.10\Omega)$	JIS C 5201-1 4.24 40 \pm 2°C, 90~95% R.H., Max. working voltage for 1000 hrs with 1.5 hrs "ON" and 0.5 hrs "OFF"
Dry Heat	$\pm(1.0\%+0.05\Omega)$	$\pm(1.5\%+0.10\Omega)$	JIS C 5201-1 4.23.2 IEC 60115-1 2.23.2 at +155°C for 1000 hrs
Bending Strength	$\pm(1.0\%+0.05\Omega)$	$\pm(1.0\%+0.05\Omega)$	JIS C 5201-1 4.33 IEC 60115-1 4.33 Bending once for 5 seconds 2010, 2512 sizes: 2mm Other sizes: 3mm
Solderability	95% min. coverage		JIS C 5201-1 4.17 IEC 60115-1 4.17 245 \pm 5°C for 3 seconds
Resistance to Soldering Heat	$\pm(0.5\%+0.05\Omega)$	$\pm(1.0\%+0.05\Omega)$	JIS C 5201-1 4.18 IEC 60115-1 4.18 260 \pm 5°C for 10 seconds
Voltage Proof	No breakdown or flashover		JIS C 5201-1 4.7 IEC 60115-1 4.7 1.42 times RCWV (RMS) for 1 minute
Leaching	Individual leaching area $\leq 5\%$ Total leaching area $\leq 10\%$		JIS C 5201-1 4.18 IEC 60068-2-58 8.2.1 260 \pm 5°C for 30 seconds
Rapid Change of Temperature	$\pm(0.5\%+0.05\Omega)$	$\pm(1.0\%+0.05\Omega)$	JIS C 5201-1 4.19 IEC 60115-1 4.19 -55°C to +155°C, 5 cycles

■ Storage Temperature: 25 \pm 3°C; Humidity < 80%RH

Packaging

Reel Specifications & Packaging Quantity

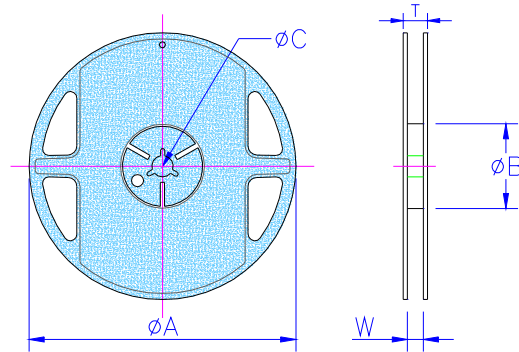

Unit: mm

Type	Packaging Quantity		Tape Width	Reel Diameter	ΦA	ΦB	ΦC	W	T					
HVR02	Paper	10K	8mm	7 inch	178.5±1.5	60 ^{+1/-0}	13.0±0.2	9.0±0.5	12.5±0.5					
		20K												
		40K												
HVR03 HVR05 HVR06	Paper	5K	8mm	10 inch	254±1	100±0.5	13.0±0.2	9.5±0.5	13.5±0.5					
		10K												
		13 inch								330±1	100±0.5	13.0±0.2	9.5±0.5	13.5±0.5
		20K												
HVR0A HVR12	Embossed	4K	12mm	7 inch	178.5±1.5	60 ^{+1/-0}	13.0±0.5	13.0±0.5	15.5±0.5					
		8K		10 inch	250±1	62±0.5	13.0±0.5	12.5±0.5	16.5±0.5					

Paper Tape Specifications

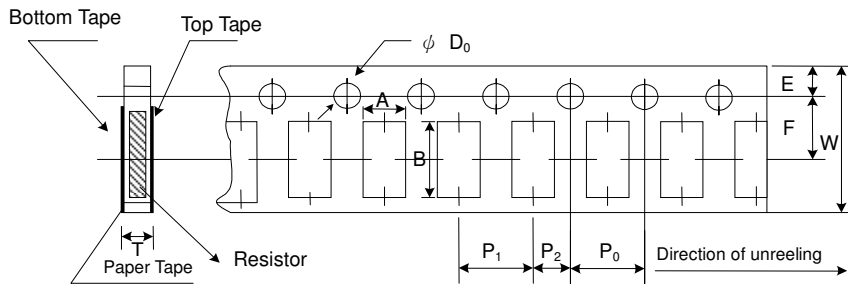

Unit: mm

Type	A	B	W	E	F	P ₀	P ₁	P ₂	ΦD ₀	T
HVR02	0.65±0.10	1.15±0.1	8.0±0.2	1.75±0.1	3.50±0.05	4.00±0.10	2.00±0.05	2.00±0.05	1.50+0.1,-0	0.45±0.1
HVR03	1.10±0.10	1.90±0.1	8.0±0.2	1.75±0.1	3.50±0.05	4.00±0.10	4.00±0.05	2.00±0.05	1.50+0.1,-0	0.70±0.1
HVR05	1.60±0.10	2.40±0.2	8.0±0.2	1.75±0.1	3.50±0.05	4.00±0.10	4.00±0.05	2.00±0.05	1.50+0.1,-0	0.85±0.1
HVR06	1.90±0.10	3.50±0.2	8.0±0.2	1.75±0.1	3.50±0.05	4.00±0.10	4.00±0.05	2.00±0.05	1.50+0.1,-0	0.85±0.1

Embossed Plastic Tape Specifications

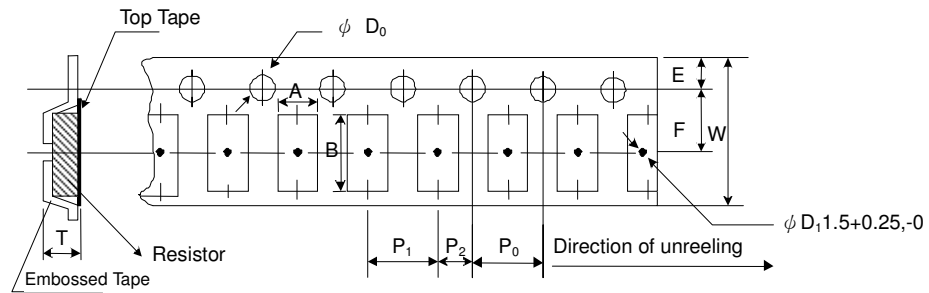

Type	A	B	W	E	F	P ₀	P ₁	P ₂	ΦD ₀	T	Unit: mm
HVR0A	2.8±0.10	5.5±0.10	12.0±0.3	1.75±0.1	5.5±0.05	4.00±0.10	4.00±0.1	2.00±0.05	1.50+0.1, -0	1.2 ⁺⁰	
HVR12	3.5±0.10	6.7±0.10	12.0±0.3	1.75±0.1	5.5±0.05	4.00±0.10	4.00±0.1	2.00±0.05	1.50+0.1, -0	1.2 ⁺⁰	

■ Marking

No marking for 0402

1% for 0805/1206/2010/2512: 4 digits marking

Example:

Resistance	100Ω	2.2KΩ	10KΩ	49.9KΩ	100KΩ
Marking	1000	2201	1002	4992	1003

5% for 0603/0805/1206/2010/2512: 3 digits marking in E24

Example: 101=100Ω 102=1KΩ (1st and 2nd are E24 code and 3rd code is multiplier)

E24 code	10	11	12	13	15	16	18	20	22	24	27	30	33	36	39	43	47	51	56	62	68	75	82	91
----------	----	----	----	----	----	----	----	----	----	----	----	----	----	----	----	----	----	----	----	----	----	----	----	----

1% for 0603: 3 digits marking in E96



3 digits marking for Example: 14C=13K7Ω 13C=13K3Ω

68B=4K99Ω 68X=49.9Ω

Marking Table

Code	E96	Code	E96	Code	E96	Code	E96				
01	100	25	178	49	316	73	562				
02	102	26	182	50	324	74	576				
03	105	27	187	51	332	75	590				
04	107	28	191	52	340	76	604				
05	110	29	196	53	348	77	619				
06	113	30	200	54	357	78	634				
07	115	31	205	55	365	79	649				
08	118	32	210	56	374	80	665				
09	121	33	215	57	383	81	681				
10	124	34	221	58	392	82	698				
11	127	35	226	59	402	83	715				
12	130	36	232	60	412	84	732				
13	133	37	237	61	422	85	750				
14	137	38	243	62	432	86	768				
15	140	39	249	63	442	87	787				
16	143	40	255	64	453	88	806				
17	147	41	261	65	464	89	825				
18	150	42	267	66	475	90	845				
19	154	43	274	67	487	91	866				
20	158	44	280	68	499	92	887				
21	162	45	287	69	511	93	909				
22	165	46	294	70	523	94	931				
23	169	47	301	71	536	95	953				
24	174	48	309	72	549	96	976				
Code	A	B	C	D	E	F	X	Y			
Multiplier	10 ⁰	10 ¹	10 ²	10 ³	10 ⁴	10 ⁵	10 ⁻¹	10 ⁻²			

Recommend Land Pattern

Unit: mm

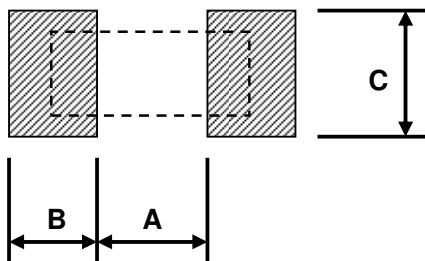

Type	A	B	C
HVR02	0.50	0.45	0.60
HVR03	0.90	0.60	0.90
HVR05	1.20	0.70	1.30
HVR06	2.00	0.90	1.60
HVR0A	3.80	0.90	2.80
HVR12	3.80	1.60	3.50